



Combine EPA II-certified, energy-efficient performance with an attractive style that is customizable to individual taste. Powerful heating and long burn times make these zero-clearance fireplaces great for heating large spaces.

LENNOX
HEARTH PRODUCTS

DAVE LENNOX
signature
COLLECTION™



Brentwood™ LV shown with clean-face panel kit installed.

■ The Brentwood™ and Brentwood LV (Linear View) fireplaces blend timeless beauty and 86.6% efficiency to offer exceptional wood-burning units. With their advanced combustion and heat-circulating features, these fireplaces let you enjoy unsurpassed warmth and temperature control. Each model offers distinct designs to create the perfect atmosphere of style and comfort in any home. Choose the Brentwood for a realistic masonry-built appearance, or select the Brentwood LV's sleek, clean-face panel option for a more contemporary look. Either way, you'll make a sophisticated statement and take pleasure in lasting comfort. ■

STANDARD FEATURES

Zero clearance to combustibles

Meets EPA II and Washington State emissions requirements (3.7g/hr)

55,000 BTU/hr heat output*

86.6% efficiency*

Airtight combustion chamber delivers maximum efficiency

All-in-one Double Air Combustion Control includes air boost for faster wood ignition and main air control for variable heat output

Ceramic glass for added safety and optimum heat transfer

Fully insulated on top, sides and bottom

Efficient air wash system keeps glass clean

Knock-out sides and back for straightforward connection to optional forced-air system

Single-door design provides an unobstructed view of the fire

Heat-resistant door handle stays cool to the touch

Backed by the Good Housekeeping Seal



Brentwood™ fireplace



Brentwood LV fireplace

Brentwood™

Textured refractory-lined firebox fashions a traditional masonry appearance

Ornate louvers create an eye-catching design

Optional 200-CFM blower

Black-painted, 24-carat gold-plated and brushed nickel cast-iron doors

Rigid firescreen

Brentwood LV

Smooth refractory-lined firebox fashions a modern appearance

Choice between clean-face panel** option for a contemporary design or elegant louvers for a more traditional look

Factory-installed 175-CFM blower with easy access for simple field service

OPTIONAL FEATURES

Gravity air distribution kit

Masonry installation with TUBINOX rigid stainless steel liner

Forced-air kit



Black-painted cast-iron door

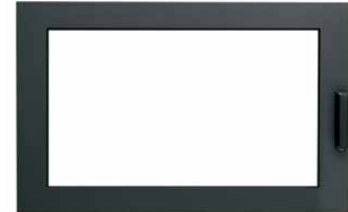

Black-painted steel door



Brushed nickel cast-iron door



24-carat gold-plated cast-iron door

*Square-foot heating capacities are approximations only. Actual performance may vary depending upon home design and insulation, ceiling heights, climate, condition and type of wood used, appliance location, burn rate, accessories chosen, chimney installation and how the appliance is operated.

**Requires gravity air distribution kit installation

DIMENSIONS

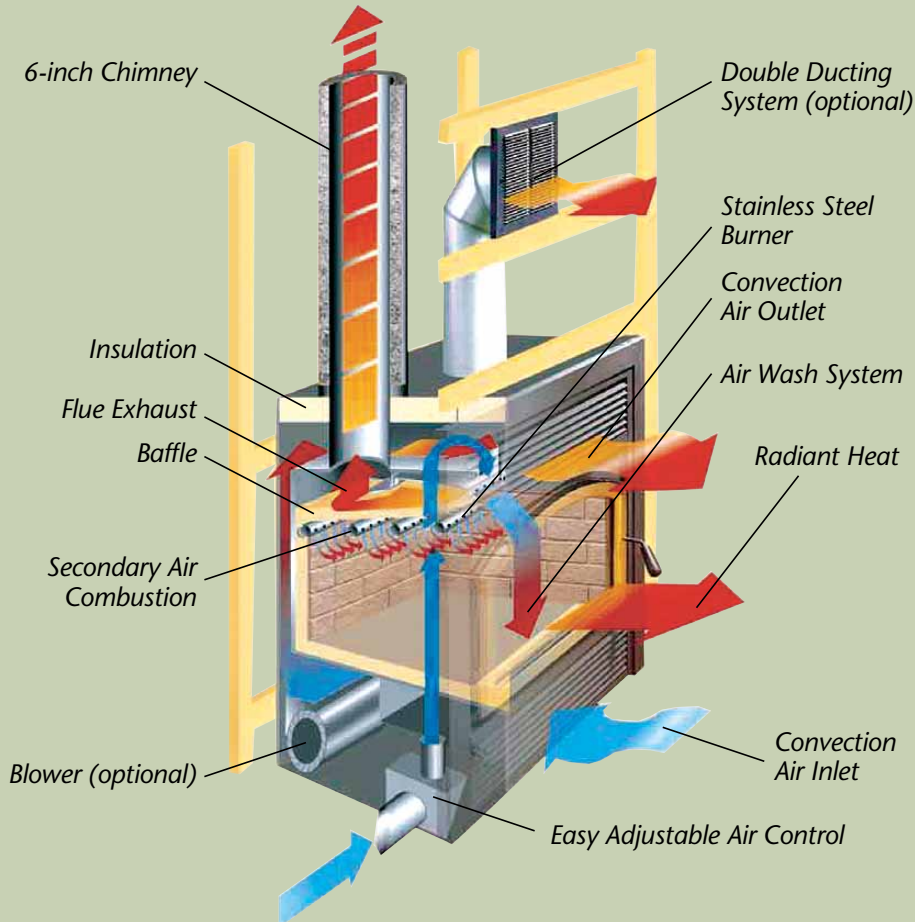
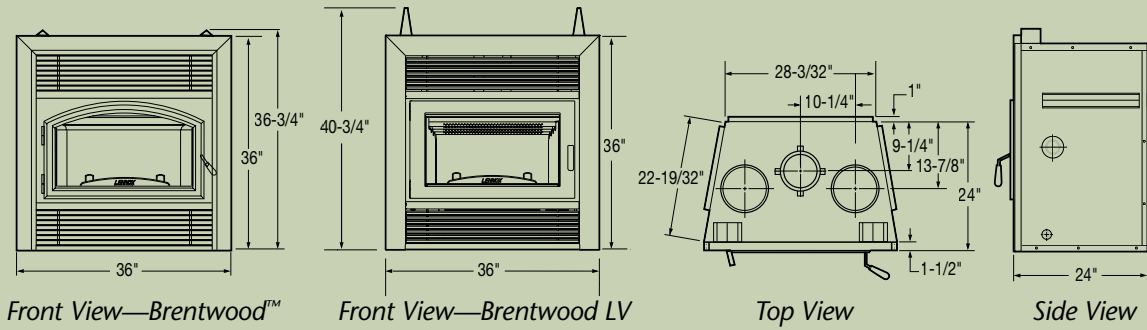

On the cover: Brentwood™ shown with clean-face panel kit installed.

PRODUCTS AND DEALERS YOU CAN COUNT ON

At Lennox, we understand how important it is for you to feel comfortable at home, so we're committed to providing you with the finest hearth products available. Choosing the right dealer for your hearth needs is every bit as important as choosing the right brand, and we think you'll agree that our dealers are a big reason why you can count on getting quality customer service when you call.

IMPORTANT NOTES:

As with any heating appliance, fireplace or stove, this appliance is extremely hot during operation. Read and understand all operating instructions before using this appliance. For further information, consult your dealer.

Actual performance may vary depending upon home design and insulation, ceiling heights, climate, condition and type of wood used, appliance location, burn rate, accessories chosen, chimney installation and how the appliance is operated.

Diagrams, illustrations and photographs are not to scale—consult installation instructions. Product designs, materials, dimensions, specifications, colors and prices are subject to change or discontinuance without notice.

Built to UL127 standards. Refer to specific installation instructions or our website for details.

LENNOX

HEARTH PRODUCTS

© Lennox Industries Inc. 2011

Visit us at www.lennox.com, or contact us at 1-800-9-LENNOX.



Report #3011202

100% recycled