



Installation of Fiberglass Pool

VIKING POOLS

Step 1. PLANNING FOR THE INSTALLATION

In planning for the installation of a new Viking Pool, there are many important considerations that must be evaluated in order to achieve a functional, long-lasting and aesthetic addition to a home. When choosing a location, consider the following:

1. **Grade:** Pools and decks are normally constructed on level ground. Extreme variations in grade should be resolved before the excavation of the pool begins. A relatively level and flat location is preferred so time and effort is not wasted on radical fluctuations in grade.
2. **Excavation Equipment Access and Pool Delivery:** Determine the most efficient route for equipment to enter and access the site. Also keep in mind that a well planned route can save time and money by enabling multiple pieces of equipment to work in unison. For example: Coordinate the delivery of the pool with the completion of the excavation and prepping of the hole. If a track excavator was used to prepare the site, it may also be utilized to unload and set the pool. Finally, consider the placement of the equipment. If possible, position the equipment so the pool can be unloaded and placed directly into the excavation.
3. **Underground Utilities:** Check with local authorities for the locations of underground water, gas, power and sewer lines.
4. **Overhead Power Lines.**
5. **Local Building Codes:** Determine the setbacks from property lines, easements, house footings, etc.
6. **Water Drainage:** Water should always drain away from the pool. Failure to keep ground water away from the exterior of the pool may result in damage to the pool that is not covered under warranty.
7. **Local Fencing Codes.**
8. **Location of Pool Equipment:** Locate to within 20' of the pool.
9. **Electrical Run for Pool Equipment.**
10. **Underground Water Conditions.**
11. **Exposure to Sunlight.**
12. **Surrounding Foliage.**
13. **View from Residence.**

TOOLS REQUIRED

- A. Transit Level
- B. Shovel
- C. Pick
- D. Rake
- E. Stakes and nails
- F. Spray paint for outlining pool
- G. String
- H. Hammer
- I. (5) 2" x 4" x 16'
- J. Tape Measures: 25' and 50' lengths



BERMUDA

Notice: Failure to read and follow specific instructions contained in this manual will void your pool warranty.

Step 2. POOL LAYOUT

When laying out the pool, note that the dimensions are to the outside edge of the pool coping. Most permit plans are measured to the water's edge. The coping of a Viking Pool is approximately 6" on all sides. There is a difference of 12" between the length and width dimensions in the installation guide and those of the permit plans. Depending on the customer and the local building inspector, this fact can be a critical consideration. Distances between the water's edge to most property lines, electrical lines, and other structures such as houses, garages, sheds and patios must be exact to plan specifications.

Start with a 12' wide by 26' long rectangle with diagonal measurements of 28'-8" (the diagonal measurements insure that your layout is square). Next, layout the center point, making sure the center lines are at 90 degrees. Stake each point around the perimeter of the pool as shown in Figure 1. Connect each stake with string to outline the pool. Use spray paint to follow the contour of the string. Remove the string and stakes, leaving only the outline of the pool.

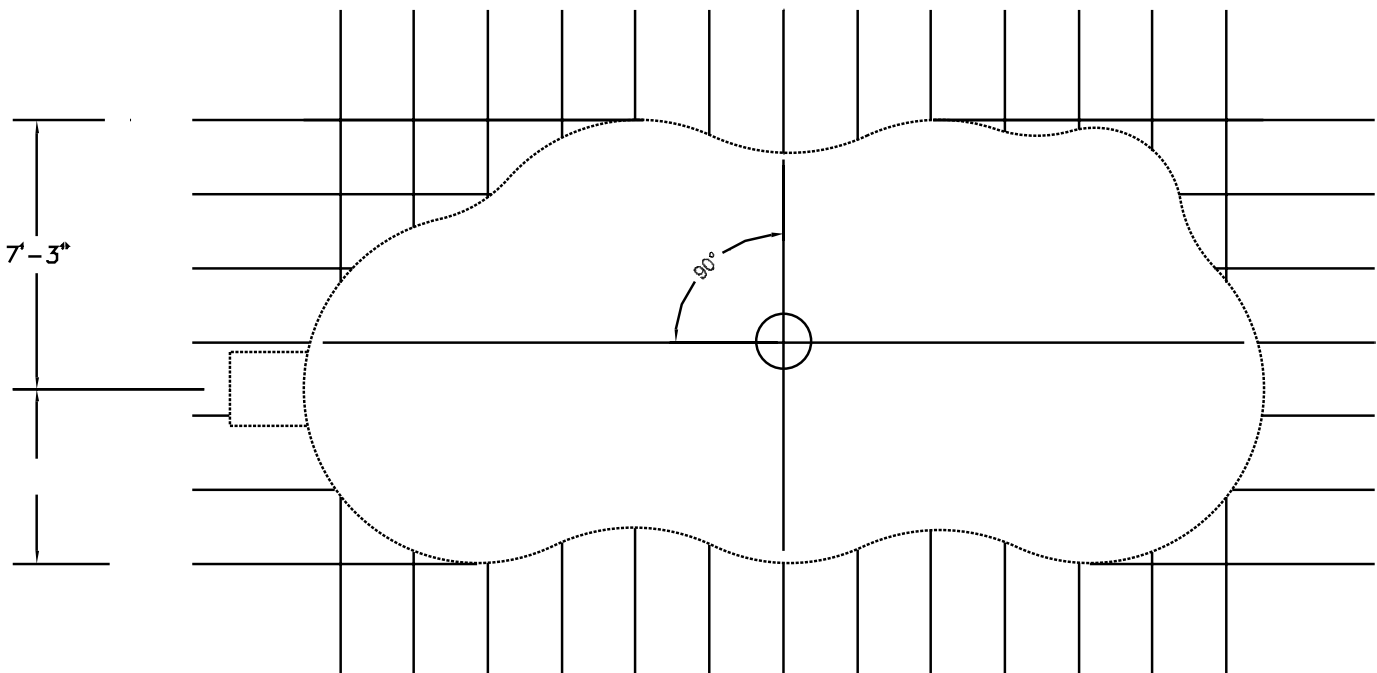

Step 3. ELEVATION

Elevation and grade of the pool area are two of the most often overlooked or miscalculated variables in the installation process. While considering all the variables concerning elevation and grade, always remember that you want water to run away from the pool. Before excavation, use the provided Installation Planning Guide to calculate all critical measurements (Form 1).

Check the four corners of the pool layout with the aid of a transit level or a sight level to determine the highest corner. This corner will be used in planning the elevation of the pool. In a typical installation, the elevation of the pool should be 4-6 inches above the existing grade around the pool. However, careful consideration should be given to pool type, size and drainage of the future pool deck, as well as the elevation of the surrounding landscape and existing structures, patios and sidewalks.

Form I INSTALLATION PLANNING GUIDE

Job: _____ Pool: Bermuda Date: _____

Finish Grade	
* Slope	-
Top of Concrete at Pool	=
Thickness of Concrete	+ 3.5"
Top of Pool	=
Shallow End Depth	+ 42" or 3'-6"
Top of Sand Shallow End	=
Thickness of Sand	+ 3.5"
Top of Dig Shallow End	=
Top of Pool	=
Deep End Depth	+ 66" or 5'-6"
Top of Sand Deep End	=
Thickness of Sand	+ 3.5"
Top of Dig Deep End	=

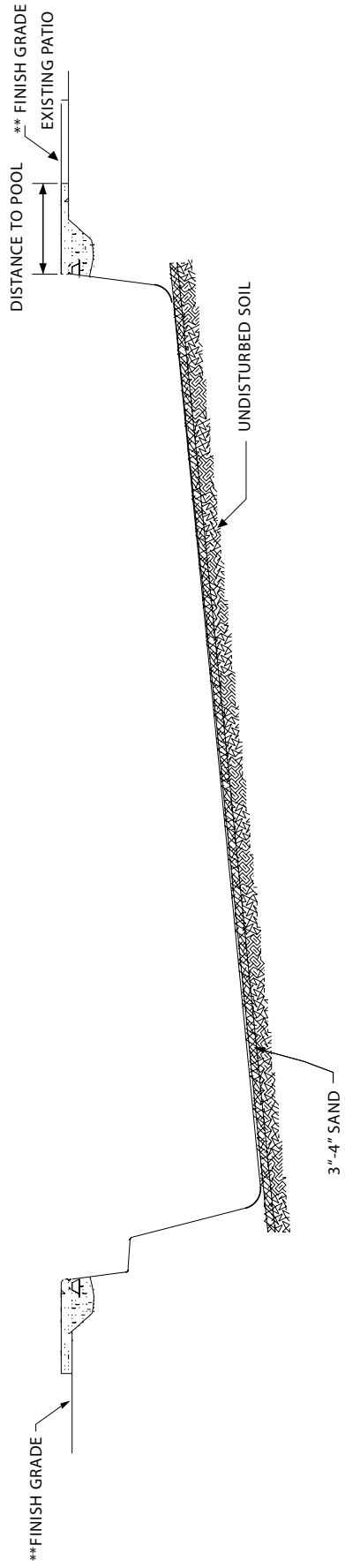

* Slope = Distance to Pool x .25 (1/4")

** If pool is independent of any existing structures or patios, finish grade is to be 3 1/2" below edge of pool deck.

Step 4. EXCAVATION

Correct excavation of the pool is very important. A hole that is too small can mean hours of picking and shoveling by hand. A hole that is too large will require extra import material, which if not dealt with properly, can result in settling or bulging of the pool.

The excavation should be dug very close to the pool size with a minimum disturbance to the unexcavated soil which will support the pool. The clearance is approximately 6" on the sides and 6" on the ends (Fig 2).

The depth of the excavation is determined with the use of a transit level and a measuring stick. The bottom of the excavation is over dug 3" to 4". This size pool will require approximately 35 to 40 yards of sand for backfill (more may be required if the pool is over dug).

The excavation should be 12' by 26', with a total depth of approximately 3' 9" (shallow end) to approximately 5' 9" (deep end) from the desired elevation of the pool. It can be helpful to give yourself extra room the first 6" in width and 12" in depth of the hole, to get past the coping, and allow space for the skimmer and the main drain. Also, keep in mind that the wall of our pools are tapered, usually 1" in for every 12" in depth. A place for the skimmer must also be dug in the side of the excavation wall. The skimmer cutout should be 2' by 2' and 3' deep. See Figure 1. for placement.

If dramatic over digging occurs in the bottom of the hole, never use excavated material to fill in the hole to the desired depth. The material will settle. We suggest road base (a tamper may be needed) compacted thoroughly, and topped with sand. If the sides of the hole are dramatically over dug, road base should be used beyond the six inches of sand. Both should be compacted thoroughly during the backfill process. In the case of over excavation on the sides of the pool in seasonal high water or poor drainage areas, you may want to mix 10% Portland cement to the backfill for stabilization.

In areas that experience seasonal high water or experience considerable water seepage during excavation, a permanent sump line (see Cross Section A-A) must be installed to alleviate the excess water and the associated hydrostatic pressure accompanying it. Viking suggests digging an 18" x 8" x 18" trench across the deep end of the excavation. Six inches of 1 1/2" rock should be placed in the bottom of the trench. A joint of 3" perforated PVC pipe is placed on the rock base and connected to a vertical stand of 8" PVC pipe running to the surface of the excavation. The 8" PVC should be trimmed with a skimmer ring and lid for aesthetics and safety. After the connection has been to the vertical stand of 8" PVC, finish covering the 3" perforated PVC pipe with 1 1/2" to 2" rock to the bottom of the excavation (See Cross Section A). Cover the new sump line with fabric. The bottom of the excavation is now ready for 3" to 4" of sand bedding.

Figure 2

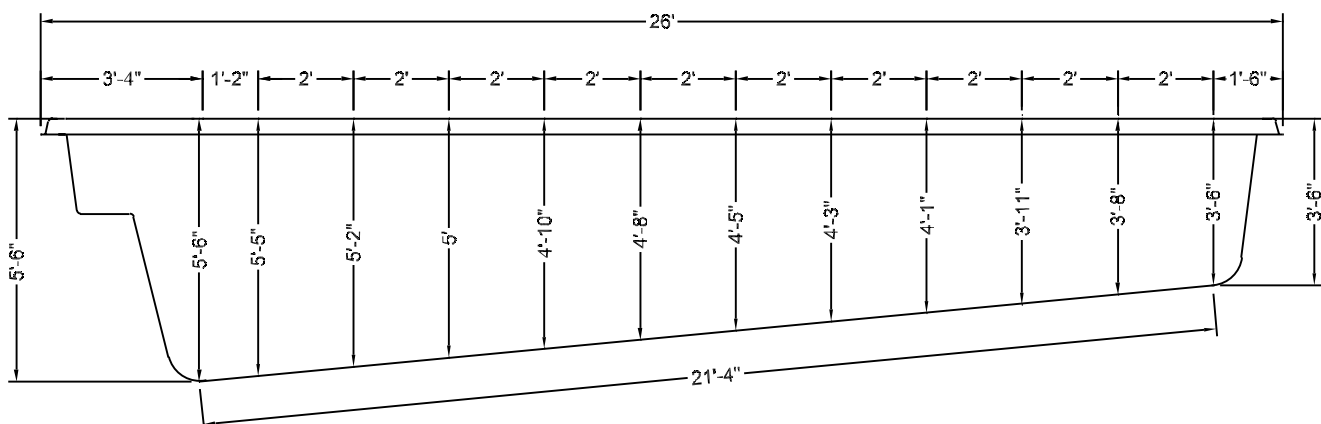

Step 5. PREPARATION OF THE BOTTOM SURFACE OF THE EXCAVATION

The preparation of the excavation bottom is critical so the pool will fit properly. Thorough preparation will eliminate settling, stress cracks and a minimum of time will be spent setting the pool.

First, install 2" x 4" screed rails length wise on both sides of the excavation, using wood or metal stakes (Fig 3). Make sure the diagonal measurement is exact to insure that the bottom is square. Adjust the screed rails to the appropriate height using a transit (see Figure 2). Next, spread a layer of sand 3" to 4" evenly over the bottom of the excavation. Rake the sand flat to the top of the screed rails (Fig 3). Compaction of the sand is achieved by the use of water and walking over the entire bottom using your body for weight. Rake and compact the area several times. Screed the bottom of the excavation, filling any low spots as you go. The completed area will resemble a slab of finished concrete. Remove the screed rails and fill in the voids with sand, being careful not disturb the sand.

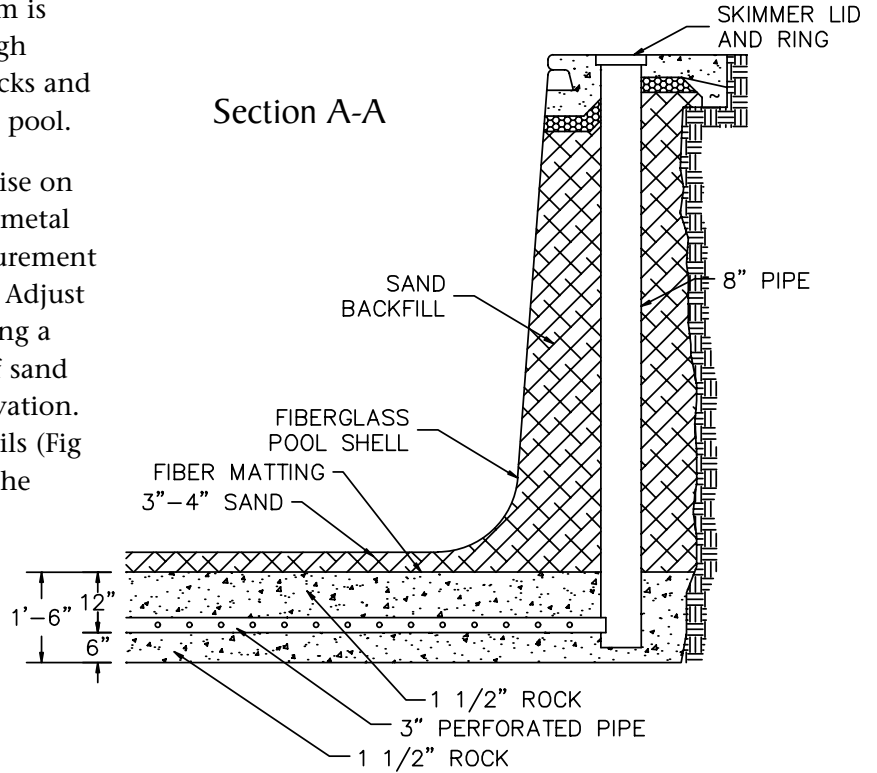
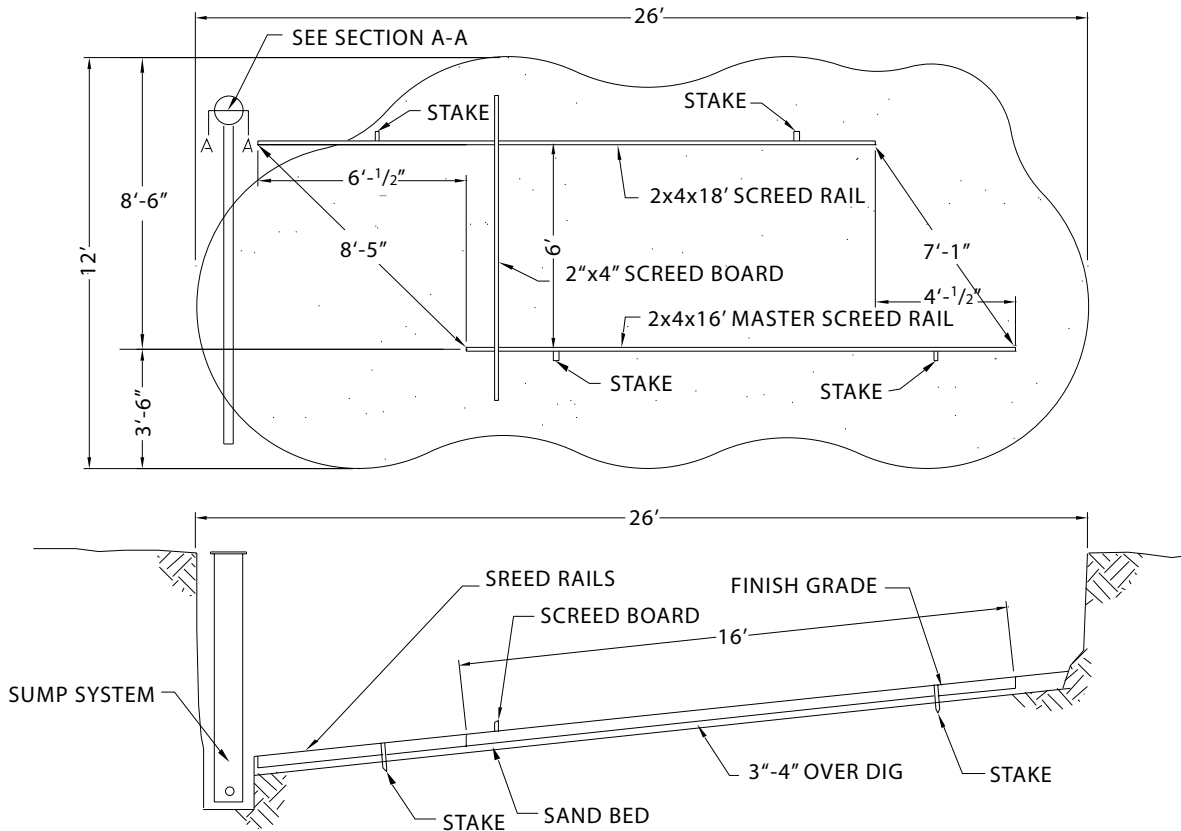

Figure 3



Step 6. SETTING THE POOL

Your pool will arrive on a truck-trailer combination. Be sure to inspect the pool for damage that may have occurred during transportation and for conformity to order specifications. A crane or excavator will lower the pool into the excavation. Please note that Viking recommends lifting all pool models over 12' wide with a spreader bar and 20' lifting straps. Once the pool is set in the excavation, the pool should be checked for level and the bottom should be walked over to detect any voids in the sand that might be present. The pool is then lifted and reset as many times as necessary to achieve a "good fit". A good fit is realized by raking the surface of the sand in order to see where the pool's perimeter is touching (footprint) after it is removed and also by walking around on the inside of the pool to detect low spots. It is normal to feel a slight void under the center of the pool. This will disappear under the weight of the water. It is important to make certain that the bottom perimeter and all transition points are sitting firmly against the sand bed. The pool can be separated from the lifting equipment when the entire perimeter of the pool (including all transitions) leaves a clear footprint and the pool is within 1/2" of level.

A properly prepared hole should not require the filling of large voids beneath the pool. Blindly washing sand beneath a pool can cause more harm than good. It is important that any adjustments to the pool's elevation be made before water is added. If a pool was properly set, nothing more than a few minor adjustments should be needed.

Step 7. WATER AND BACKFILL

"Locking in" is the process of placing and tamping the first 6" of backfill around the radius of the pool to hold it firmly in place during the installation process. After your pool is "locked in, start the water in the pool and continue the backfill process. The level of water in the pool and the level of sand outside the pool should be within 6" of each other. Continue filling the pool and backfilling until 4" to 6" of water are in the pool. Check the level of the pool. If the pool was properly "locked in", no adjustments should be necessary. If any movement has occurred, small adjustments must be made at this time by placing a lever assembly under the coping of the pool (Fig 4.). If adjustments are needed, (low condition) raise the pool to the proper height and place sand under the pool. When the proper height is achieved, continue the filling and backfilling process. If the pool is too high, remove sand as needed. It is very important that the radiuses of the pool are packed properly. Poorly packed radiuses can result in hairline cracks or structural cracks due to deflection. Be sure to backfill slowly and thoroughly. When the proper height is achieved, continue with the filling and backfilling process.

After approximately 12" of water is in the pool and backfill has been placed evenly, the backfill should be allowed to precede the water by 6". As the water approaches the shallow end, pay particular attention to all the unsupported areas of the pool. Steps and swimouts tend to droop, so slight adjustments may need to be made with the levering device as mentioned before (Fig 4). Be sure you wait until a sufficient amount of water surrounds the area (usually 12") to keep the rest of the pool in place, or you may raise more than you intend. The walls of the pool may bulge inward if too much

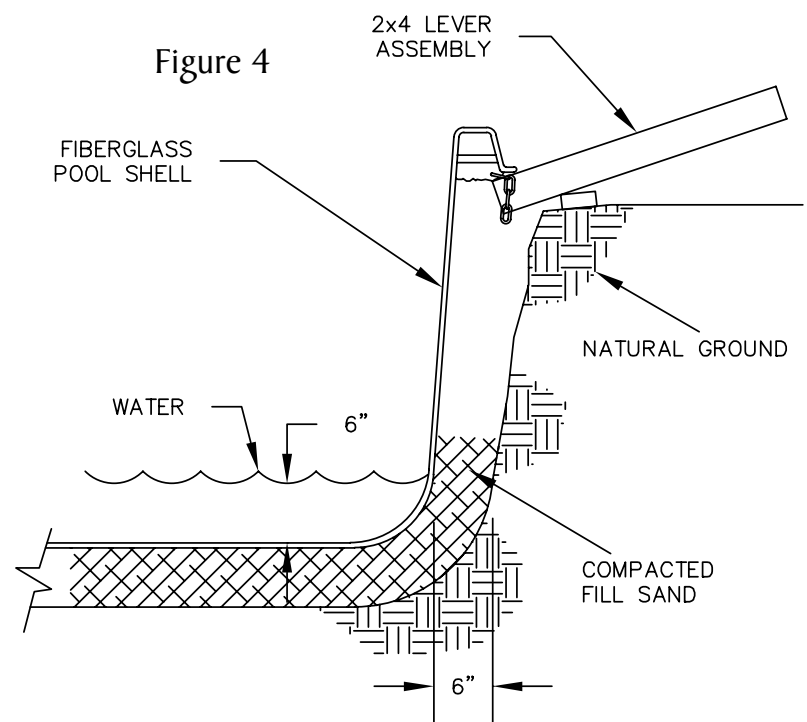

backfill has preceded the water in the pool, or outward if too much water precedes the backfill. If bulging does occur during the installation, the only remedy is to dig that area out and proceed correctly. Slight bulging has only visual effects, while not affecting the structure of the pool. A string line is very useful in determining the straightness of the pool walls during the backfilling process.

Step 8. PLUMBING

When the water and backfill levels are close to reaching any of the pool inlets, stop the filling and backfilling process and run the plumbing pipes along the excavation cavity and route them to the equipment site. After the plumbing is installed, complete the filling and backfilling process.

A basic swimming pool circulation system is relatively simple in operation. Water in the pool is drawn through the main drain and skimmer to the pump, which pushes it through the filter back to the pool via the returns. Refer to Figure 5 for a basic filtering system diagram. See your contractor for more advanced filtering systems that may include sanitizers, jets, blowers, automatic pool cleaners, etc. Viking recommends the use of schedule 40, 2" plumbing on most pools. Visually inspect all plumbing installed at the factory upon the delivery of the pool and during the backfill process.

To prevent accidentally draining the pool, Viking suggests placing the equipment at or slightly above the elevation of the pool and plumbing the pool so that the water leaves the pool via the skimmer and not the main drain. You should not place the equipment higher than 6" above pool level. The equipment becomes less efficient the greater the distance away from the pool. If the equipment is placed below the water level, shut off valves must be installed to prevent accidental siphoning of the pool. Pipes may now be glued at the equipment pad and circulation of the filtering system may begin. Check all connections for leaks and proper circulation before covering them. Local building codes may require pressure testing of the plumbing system before the installation is complete.

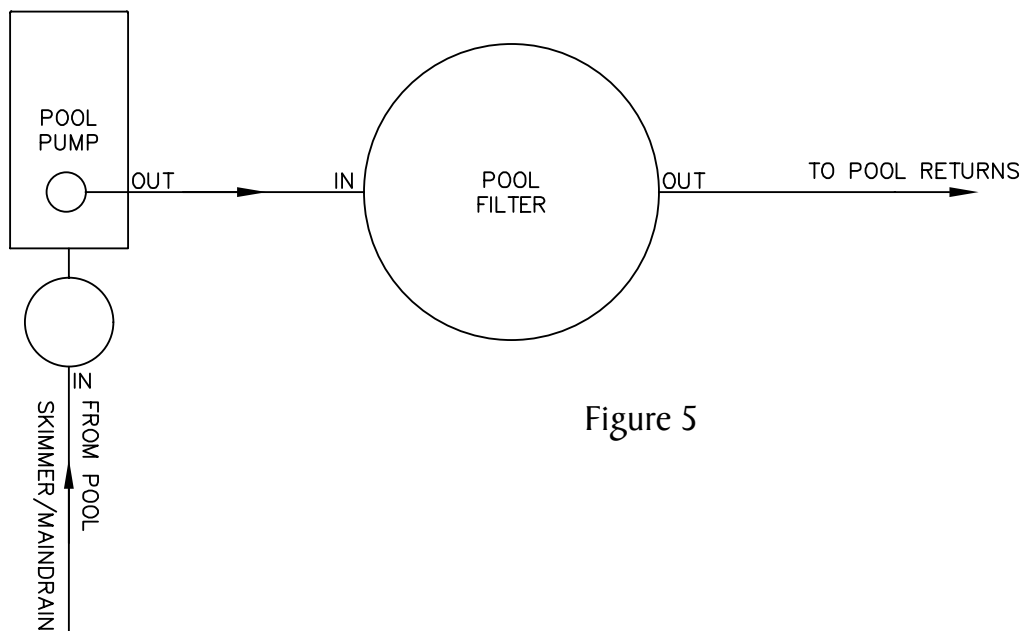

Figure 5

Step 9. ELECTRICAL

If the installer or homeowner is not qualified to do electrical work, an electrician should be hired and a building official should inspect the work. All electrical work should be done to National Electric Code specifications and any local codes. Viking Pools does not recommend wet niche lights, but rather the use of fiber optic lighting. Wet niche lights have a tendency to corrode and leak. Fiber optic lights are easy to install, versatile, and do not require a bonding inspection, which can delay installation. Viking Pools will not be held responsible for any electrical work.

Step 10. POURING CONCRETE

Forms are now put up around the perimeter of the pool. Half inch holes may be drilled into the lip of the pool every 3'. Two foot lengths of 3/8" rebar are placed in each hole and bent at 90 degree angles (Fig 6-7). This will ensure a bonding or anchoring effect on the sides of the pool. The walkway may also be reinforced with 6" No. 10 wire mesh or No. 3 rebar on 2' centers (Fig 6-7). Viking Pools recommends concrete decking. Concrete should be poured at least 3' around the perimeter of the pool and at least 4" deep. Viking Pools will not be held responsible for any concrete work or cracks that may result from its use.

Figure 6 Concrete Deck with Brick or Stone

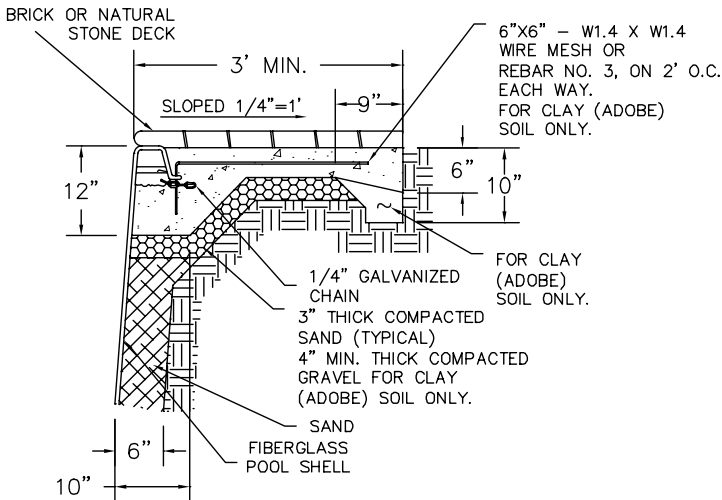

* For non cantilever decks remove stone or bricks.

Figure 7 Typical Cantilever Concrete Deck

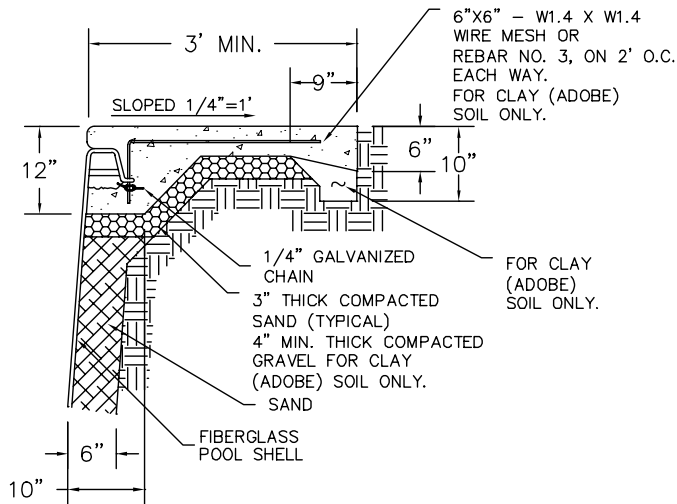

Figure 8 Typical Bond Beam Construction

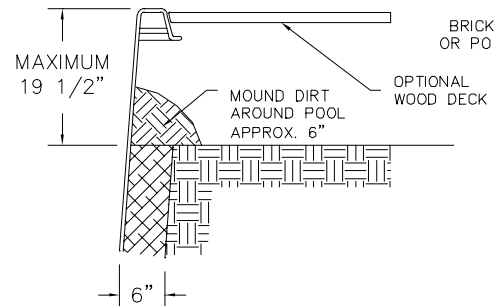
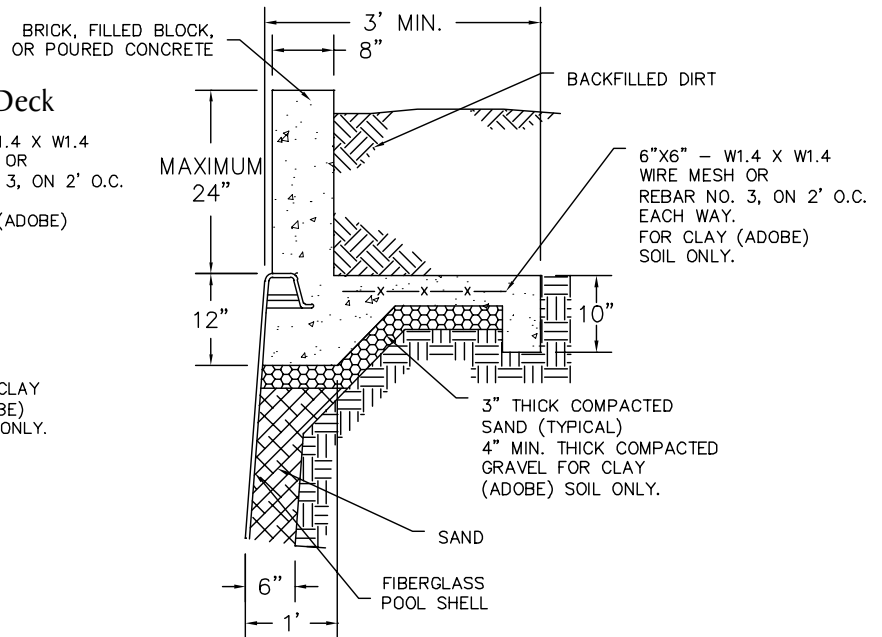

Figure 9 Typical Bond Beam Construction



WARNING TO THE BUYER

This pool is designed to be kept full at all times. The shell could be damaged if the water level is allowed to drop below the skimmer. When appreciable draw-down is noticed, or if it becomes necessary to drain the pool, contact Viking Pools, or their agents for instructions. The pool shell may be damaged and separation from the concrete may occur if the pool is allowed to overflow or if heavy water drainage is allowed to over-run the deck to pool shell connection. Keep the water level in the middle of the skimmer. Viking Pools will not be held responsible for any unforeseen problems or circumstances which arise from inadequate site drainage or incorrect deck installation. Refer to the Viking Pools Warranty sent with the pool for conditions, circumstances, or installation practices that may void the pool's warranty.